

| SPECIFICATIONS | |
|------------------------|--|
| FREQUENCY: | 2-30 MHz WITH TURNER (NOT SUPPLIED) |
| POWER RATING: | 1 KW |
| POLARIZATION: | VERTICAL |
| CONSTRUCTION: | SHAKESPEARE FIBERGLASS PROCESS (ANTENNA SECTIONS) |
| ENVIRONMENT: | FOR ALL WEATHER ENVIRONMENTS |
| SALT FOG RESISTANT: | 5% SALINITY SOLUTION |
| OPERATING TEMP: | -40° C TO +80° C |
| RADIATION: | OMNIDIRECTIONAL |
| BASE DIAMETER: | 1.25" (NOMINAL) |
| TIP DIAMETER: | .25" (NOMINAL) |
| LENGTH: | 32' (8 SECTIONS) |
| WEIGHT: | 30 LBS (NOMINAL) |
| FINISH: | MILITARY GREEN # 23 |
| ALTITUDE: | UP TO 15,000 FT. |
| WIND RATING: | UP TO 35MPH (FOR 0.5" RADIAL ICE, REDUCE WIND RATING BY 40%) |

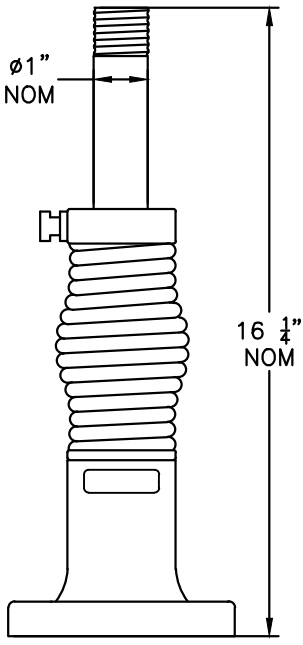

4245 (NSN:5985-01-499-4898)

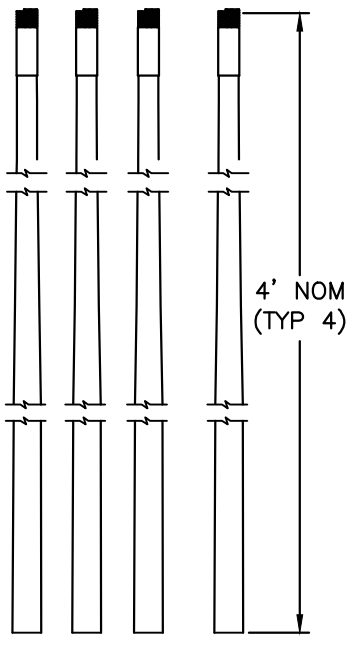
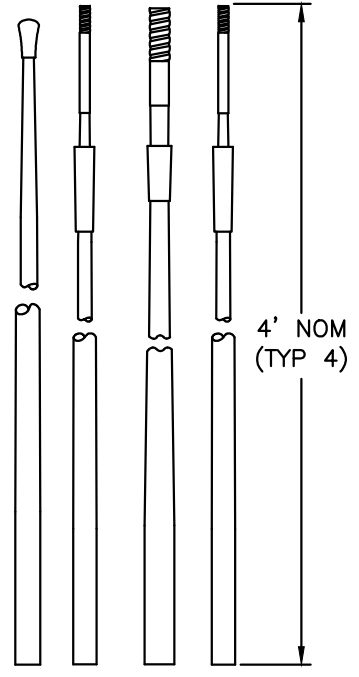

120-31 (NSN:5985-01-138-8529)

| | | | | | | | | |
|--------------------------|-------------|-------|---|--|---|---------------|-------|------|
| ENGINEERING APPROVAL BY: | | DATE: | DO NOT SCALE DRAWING UNLESS OTHERWISE SPECIFIED DIMENSIONS ARE IN INCHES. X = ± TOL_X JX = ± TOL_JX JXX = ± TOL_JXX ANGLES = ± TOL_ANG |  SINCE 1907 ELECTRONIC PRODUCTS GROUP COLUMBIA, S.C. 29203 | DRAWN | ENG APPROVAL: | SCALE | DATE |
| REV | DESCRIPTION | BY | | | DATE | TR | | - |
| | | | | | HF BASE W/32FT ANTENNA PART# 4245 & 120-31 | | | |